

# DESSIN TECHNIQUE N° 2.11 / TECHNICAL DRAWING No. 2.11

## Restricteur d'échappement OK-N Junior / Exhaust restrictor OK-N Junior

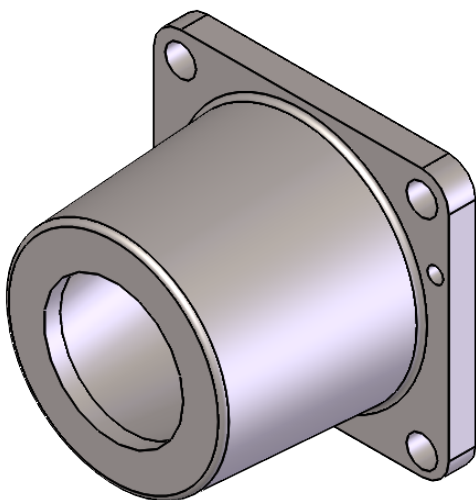
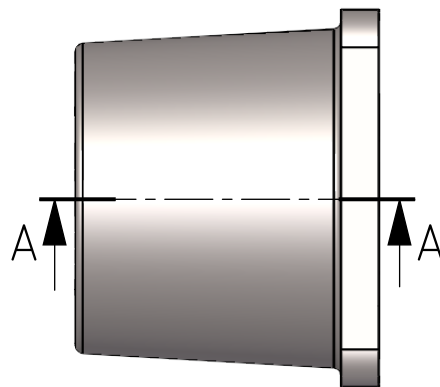
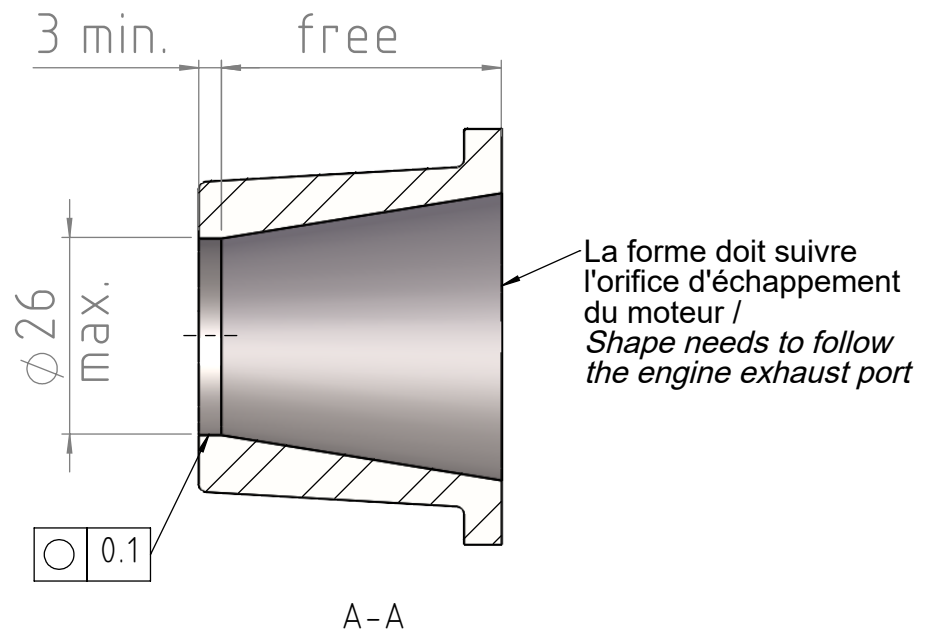

La meme construction uniforme que celle  
indiqué sur le DT /  
Same uniform construction as indicated in the TD

Matériau magnétique / Magnetic material

Dimensions in / Cotes en mm

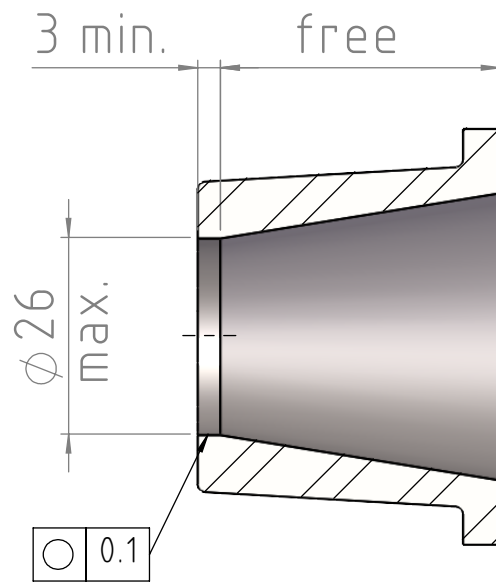

A-A

